



FigNoggle Designs

CNC Plans for Asian Mini-Mills

Asian/SIEG-made (X2) mini-mills
Harbor Freight (#44991), Grizzly (#G8689), Micro-Mark (#82573), Homier (#3947), Cummins (#7877)

FEEL FREE TO DISTRIBUTE.

NOTES:

1. THIS IS A GIB STRIP HOLDER DESIGNED FOR SIEG X2 MINI-MILL GIBS.
2. LINEAR TOLERANCES +/- 0.005".
3. ANGULAR TOLERANCES +/- 1 DEGREE.
4. SUGGESTED MATERIAL: 6061 ALUMINUM.
5. DIMENSIONS ARE IN INCHES.

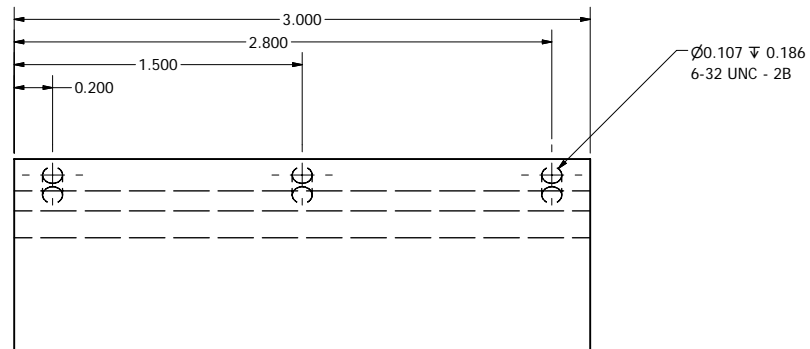
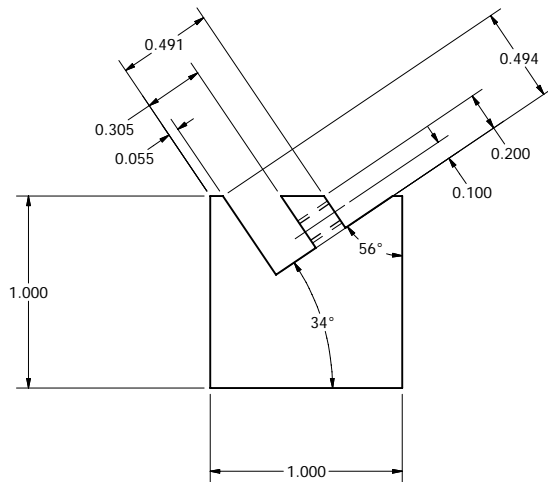
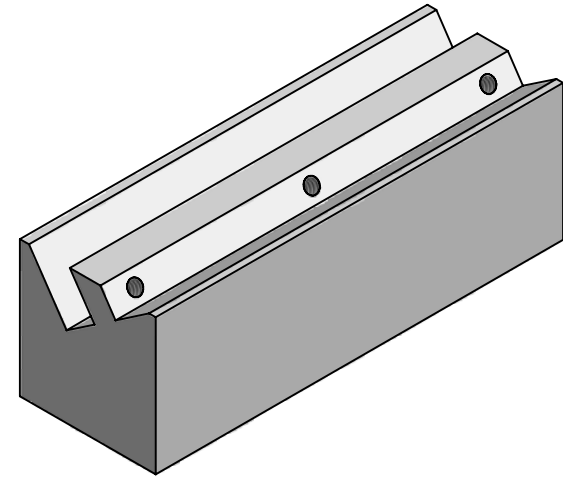

Copyright 2006. david@fignoggle.com figNoggle Designs. All rights reserved.

CNC CONVERSION PLANS FOR YOUR SIEG X2 MINI-MILL.
DRO PLANS AND MORE AT WWW.FIGNOGGLE.COM.

DRAWN david@fignoggle.com	3/23/2006	figNoggle Designs / www.fignoggle.com	
CHECKED		TITLE	
QA		GIB STRIP HOLDER FOR SIEG X2 MINI-MILL GIBS	
MFG		SIZE	DWG NO
APPROVED		C	gibStripViseBlock
		SCALE	REV
			SHEET 1 OF 1